



**Techni**  
ENGINEERING SOLUTIONS

**FIAT NEW DOBLO / VAUXHALL COMBO**  
1.6 MULTIJET 16V E5 B+ / 1.6 CDTI E5 B+

---

**CODE / CODICE: 0500.7662**

**COMPRESSOR / COMPRESSEUR /  
KOMPRESSOR / COMPRESSORE / COMPRESOR:  
SELTEC TM13 / TM15  
QUE QP13 / QP15**

---

**FITTING INSTRUCTIONS  
EINBAUANLEITUNGEN  
INSTRUCTIONS POUR LE MONTAGE  
ISTRUZIONI DI MONTAGGIO  
INSTRUCCIONES DE MONTAJE**

---



**Contents**

<b>ENGLISH</b> .....	4
Parts View.....	4
Parts List .....	5
Compressor Configurations .....	6
Standard Fastener Torque Values .....	6
Kit Details .....	7
Vehicle Details .....	7
Forward .....	7
Pre Installation.....	8
Installation .....	10
Compressor Installation.....	10
Post Installation.....	11
Drive belt Installation .....	14
Finish .....	14

**PARTS VIEW**

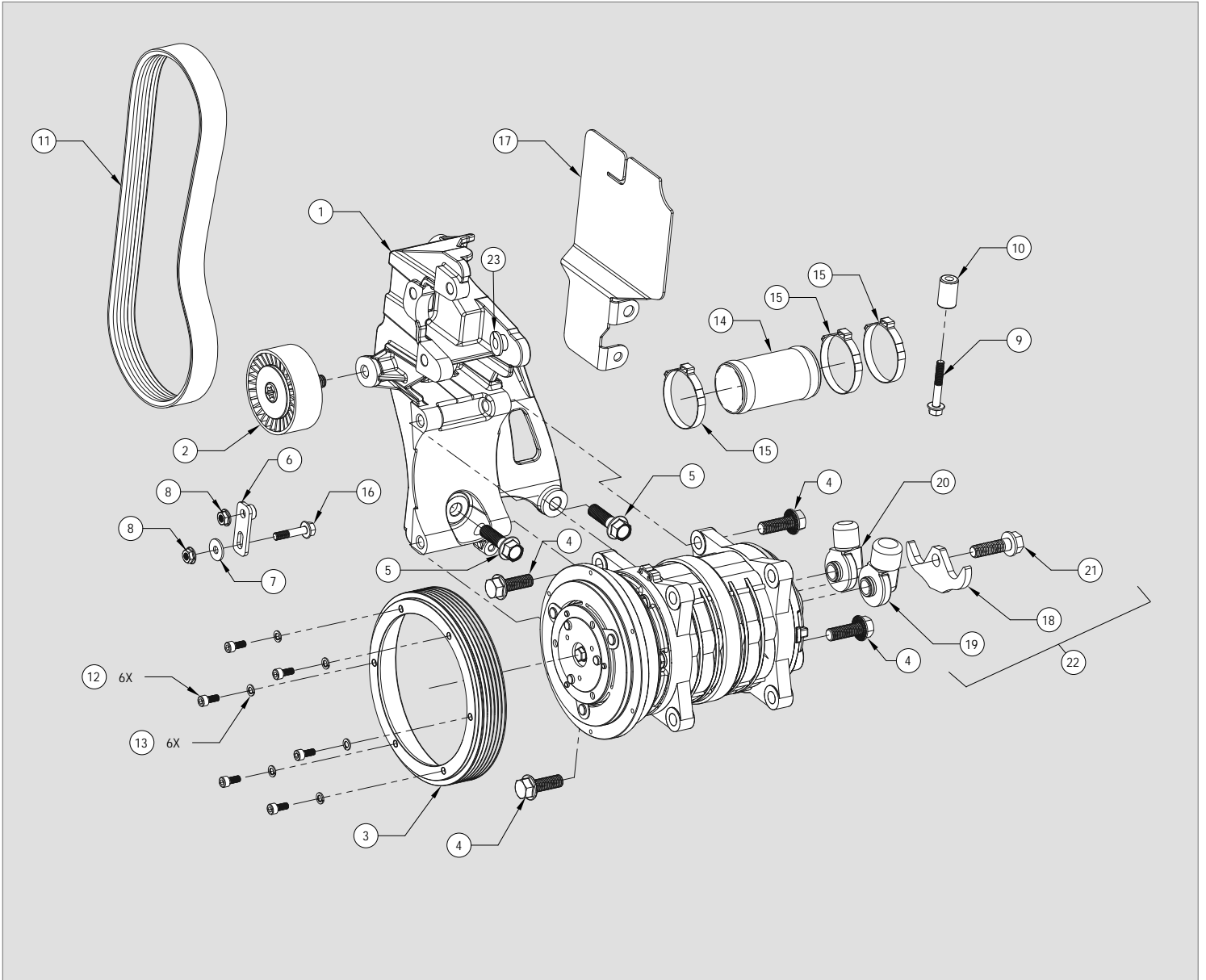

## PARTS LIST

ITEM	CODE	DESCRIPTION	QTY.	COMMENTS
1	0440.3223	Compressor Mount Bracket	1	
2	1700.5001	Idle Pulley Assembly 70 x 26 With Bolt	1	
3	0411.0333	Clutch Rotor - PV6 160 Dia 41.55 GL - Seltec	1	
4	2705.0491	Hex flange bolt Durlok - M10 x 30 : 1.50 - 12.9	4	
5	2705.5001	Hex flange bolt - M10 x 35 : 1.25 - 10.9	2	
6	3020.9143	Air Pipe Bracket	1	
7	2806.0501	M6 Penny Washer	1	
8	2732.0041	Hexagon flange nut Durlok - M6 : 1.00	2	
9	2702.0501	Hex Flange Bolt M6 X 40 : 1.00	1	
10	2803.2803	Spacer	1	
11	0820.5051	Belt - Poly Groove 6PK 1855	1	
12	2716.0031	Socket cap screw - M5 x 12 - 0.80	6	
13	2805.0031	Spring washer M5 x 1 - ID 5.1 OD 9.2	6	
14	1494.0003	Turbo Pipe Connector	1	
15	1537.1001	Turbo Pipe Clip	3	
16	2702.0511	Hex flange bolt M6 X 30 : 1.00	1	
17	3020.6341	Heat Shield	1	
18	3020.6141	Manifold pipe clamp C	1	
19	0426.5032	Compressor Fitting - Suction 7/8 -14 Type B	1	
20	0426.5042	Compressor Fitting - Discharge 3/4 -16- Type B	1	
21	2705.5301	Hex Flange Bolt -M10 x 35 : 1.50 -8.8	1	
22	0425.0621	Manifold Assembly - Que/Seltec - swivel type D- 3/4x7/8	1	
23	2803.6201	Spacer 13.0 OD x 9.01D x 16.1L	1	

**COMPATIBLE COMPRESSORS**

SELTEC	TM-13 HS	TM15-HS	TM16-HS
Comp No	0381.0492	0381.0382	-
Valeo No.	-	-	-
Mounting	Ear	Ear	-
Rotor	1A	1A	-
Armature	SL	SL	-
Diameter	126	126	-
Voltage	12	12	-
Orientation	V	V	-
Fitting	3/4 x 7/8	3/4 x 7/8	-
Manifold	Bolt	Mono	-

QUE	QP13-HD	QP15-HD	QP16-HD
Comp No	0391.0492	0391.0382	-
Que No.	QP13-1825	-	-
Mounting	Ear	Ear	-
Rotor	1A	1A	-
Armature	SL	SL	-
Diameter	126	126	-
Voltage	12	12	-
Orientation	V	V	-
Fitting	3/4 x 7/8	3/4 x 7/8	-
Manifold	Bolt	Mono	-

DELPHI	-	-	-
Comp No.	-	-	-
Delphi No.	-	-	-
Mounting	-	-	-
Rotor	-	-	-
Armature	-	-	-
Diameter	-	-	-
Voltage	-	-	-
Orientation	-	-	-
Fitting	-	-	-





SANDEN	-	-	-
Comp No	-	-	-
Sanden No.	-	-	-
Mounting	-	-	-
Rotor	-	-	-
Armature	-	-	-
Diameter	-	-	-
Voltage	-	-	-
Orientation	-	-	-
Fitting	-	-	-

**COMPRESSOR KIT CONFIGURATIONS**

PART NUMBER	COMPRESSOR KIT PART NOS					DESCRIPTION	QTY.
	0513.7662	0515.7662	0593.7662	0595.7662	0550.7662		
0381.0492	●					TM13 Ear Mount 1A SL 126 12V V 3/4 x 7/8 Bolt	1
0381.0382		●				TM15 Ear Mount 1A SL 126 12V V 3/4 x 7/8 Mono	1
0391.0462			●			QP13 Ear Mount 1A SL 126 12V V 3/4 x 7/8 Bolt	1
0391.0382				●		QP15 Ear Mount 1A SL 126 12V V 3/4 x 7/8 Mono	1
0410.0121					●	TM/QP Clutch 1A 126 OD 12V Over Hang	1

**STANDARD FASTENER TORQUE VALUES**

In the absence of specific torque values detailed in this fitting instruction manual, the following chart can be used as a guide to the maximum safe torque for specific size and grade of fastener.

STRENGTH								
	Max Torque		Max Torque		Max Torque		Max Torque	
Dia / Pitch	lb.ft	Nm	lb.ft	Nm	lb.ft	Nm	lb.ft	Nm
M5 x 0.80	2	3	4.5	6	6.5	9	7.5	10
M6 x 1.00	4	5.5	7.5	10	11	15	13	18
M8 x 1.25	10	13	18	25	26	35	33	45
M10 x 1.25	20	27	39	53	57	78	66	90
M10 x 1.50	18	25	37	50	55	73	63	86
M12 x 1.75	33	45	63	85	97	130	111	150
M14 x 2.00	55	75	103	140	151	205	177	240
M16 x 2.00	85	115	159	215	232	315	273	370

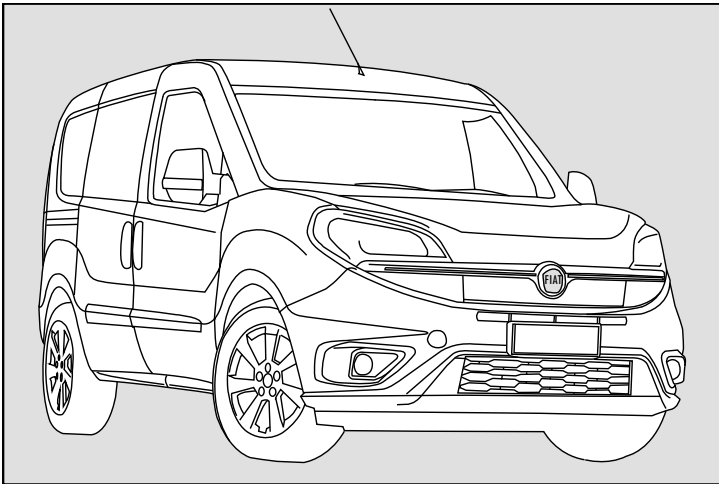

## VEHICLE DETAILS

Manufacturer	Fiat / Vauxhall
Make	Face-lifted Doblo Cargo / Combo
Model	1.6 Multijet 16V E5 b+ / 1.6 CDTi E5 b+
Engine CC	1598cc
Engine Details	198A3000 - 105 BHP
Year	2015>
Chassis Nos.	N/A
LHD	YES
RHD	YES
PAS	YES
A/C	NO
Voltage	12v

## KIT DETAILS

Kit Part No.	0500.7662
Description	Standard Kit
Compressor RPM	4125 @ Max Engine Power Output
Fitting Time	60 Minutes
Suction Fitting	90°
Discharge Fitting	90°
Belt Type	6PK 1855
Belt Part No.	0820.5051

## FOREWORD

The purpose of this manual is to facilitate the installation of a direct drive compressor. The information given is merely instructive, should any complications arise contact the Technical department. The manufacturer's warranty does not cover any problems caused by defective installation or alterations made unless authorised. The manufacturer shall not be responsible for any injury, damage or loss caused directly or indirectly as a result of using this manual or the information contained within it.

### 1 SAFETY MEASURES:

**Before fitting the Compressor adapter drive kit, ensure the following for damage:**

- a Inner and outer trim and body work
- b Engine idle pace
- c Check all the vehicle functions

**Check list:**

- a Ensure that the right kit has been selected
- b Before installing, check that all the correct pieces are present; also ensure that there are no missing or broken pieces
- c When fitting, make sure the vehicle is properly protected against damage.

### Installation apparatus

- a Calibrated torque wrench
- b Hand service tools
- c Protective covers and shields

### 2 PRECAUTIONS

- a Detach the battery negative lead.
- b Torque all bolts where stated using a calibrated torque wrench.
- c Take extreme care with moving parts.
- d Remove the vehicle's ignition key and keep it with you.
- e Wear safeguards and make sure that liquid refrigerant never touches your skin

**Caution:** Measures must be followed accurately to steer clear of the possibility of damage to individuals

**Warning:** This calls awareness to actions which must be pursued to avoid damage to the components.

**NB:** This calls awareness to make the job easier or gives useful information.

**PRE-INSTALLATION**

**N.B** Prior to commencing work, please examine the instructions with care. The alphabetical symbols on the diagram relate to written instructions, numerical symbols relate to the parts listing.

**NB:** Please refrain from using “Loctite” unless otherwise notified.

1. Remove the under panel
2. Remove the turbo hose (A) and pipe clips (B) using correct removal pliers Clic-R® - Fig 1
3. Remove the rubber air hose (C) and the top metal pipe (D) and 2 x M8 bolts (U) - Fig 2 and Fig 3

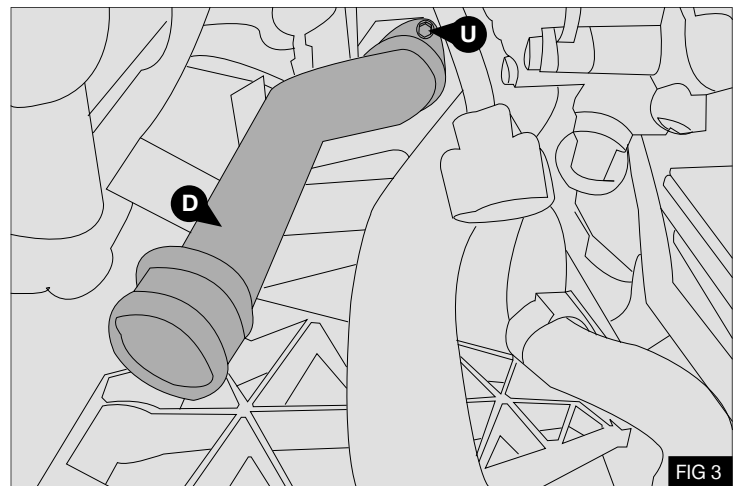
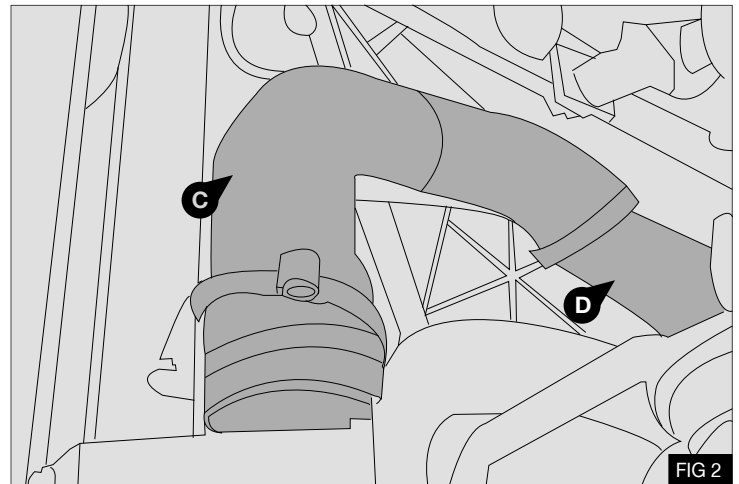
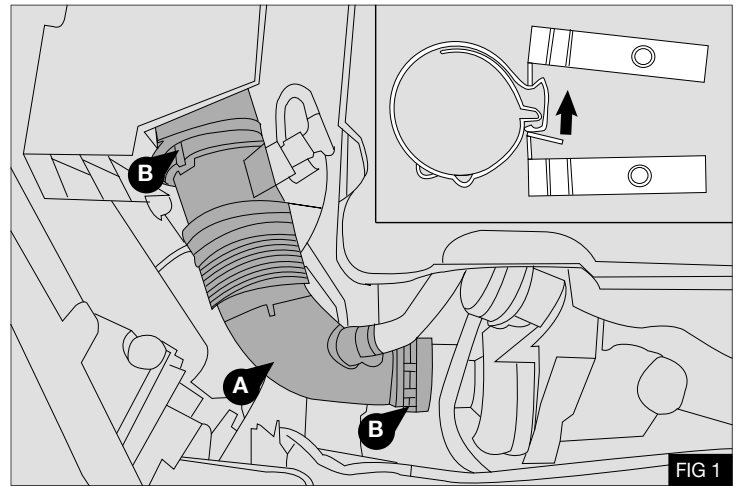

4. Remove OE bolt (E) that secures the metal air pipe (F) to the chassis - Fig 4

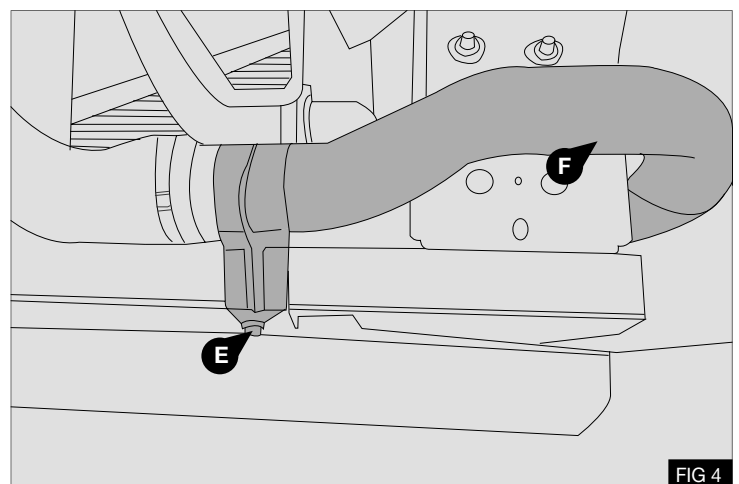



5. Remove the support bracket ③ for the pipe ⑤ off the chassis stud ④ - Fig 5

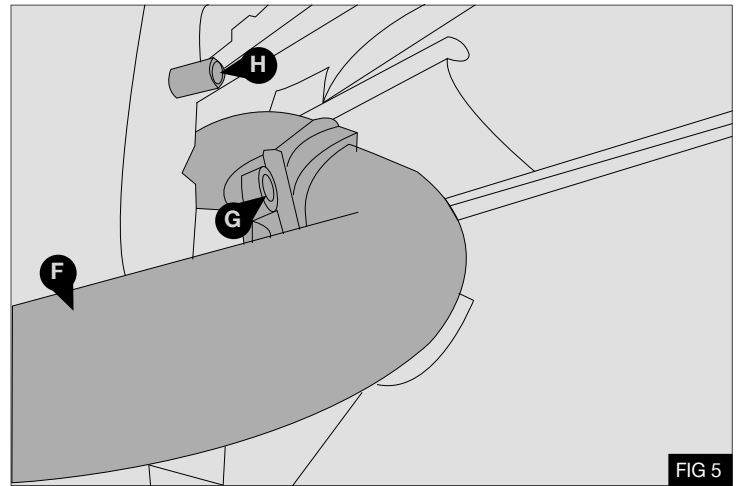

6. Cut the rubber hose ② on the line indicated in the image - Fig 6

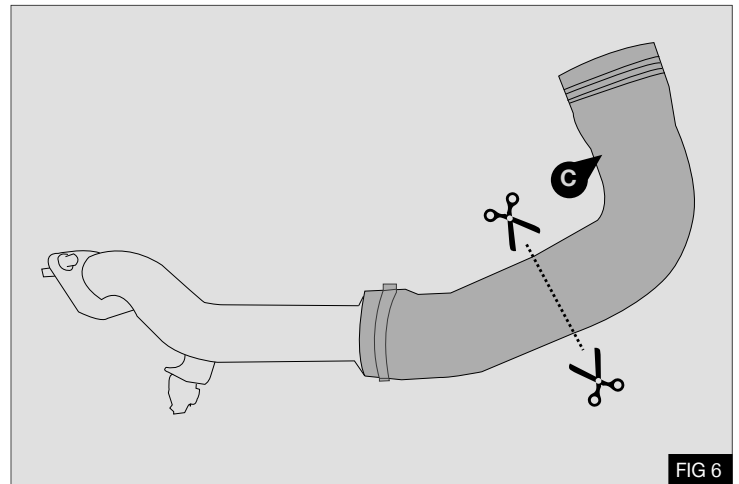

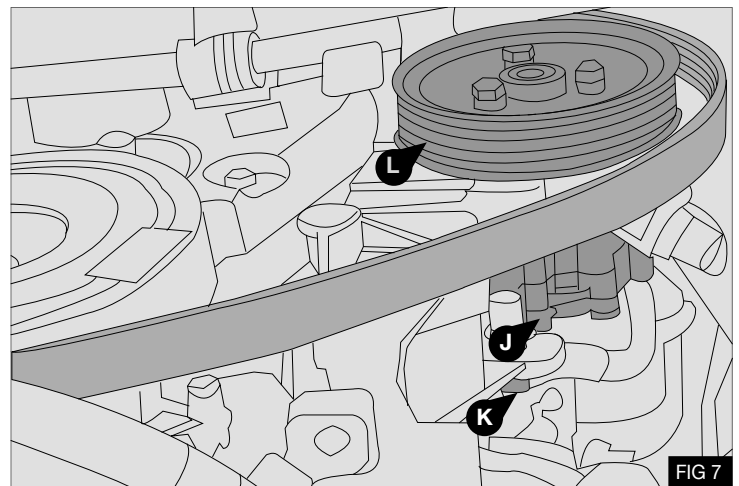

7. Remove the OE belt and the PAS pump ①. Retain the OE M8 socket head bolts ⑥ and washers for use later. Remove the PAS rotor ⑦ from the PAS pump ①. Retain the OE bolts for use later - Fig 7



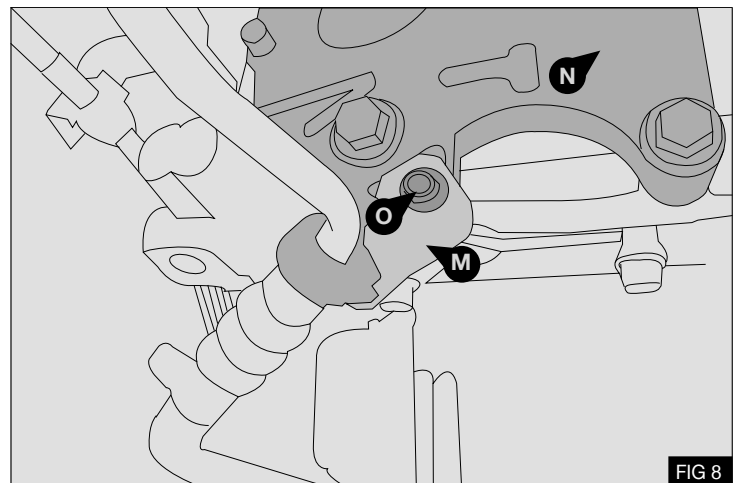

8. Remove the PAS pipe support bracket ⑩ from the OE mount bracket ⑨ and retain the M6 bolt and washer ⑪ for use later - Fig 8.

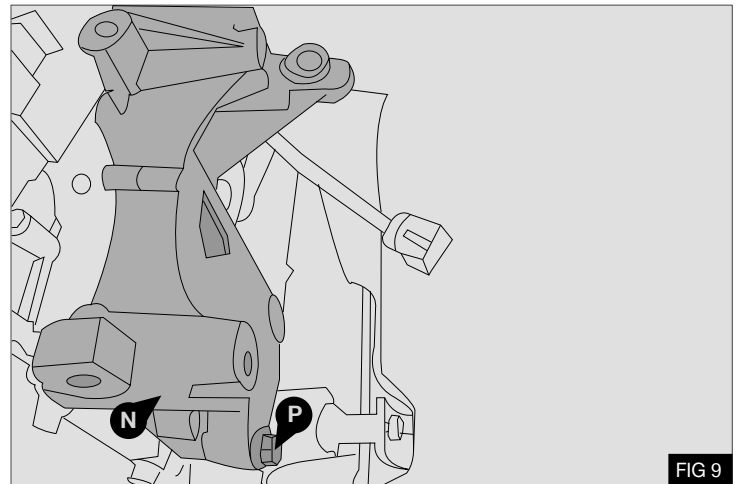

- Remove the OE mount bracket  and retain 3 of the 5 OE M10 x 45 bolts  for use later - Fig 9









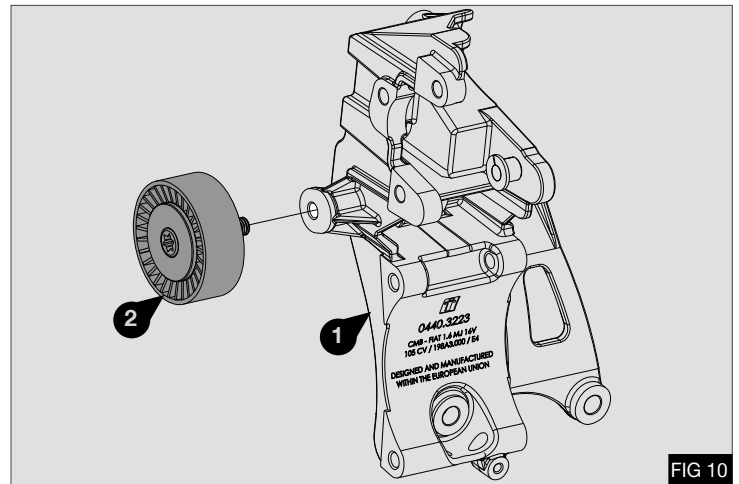

### MOUNT BRACKET INSTALLATION

- Mount the idler  onto the mount bracket  - Fig 10





Torque M10 x 30 bolt - 58 Nm / 42.7 lb.ft

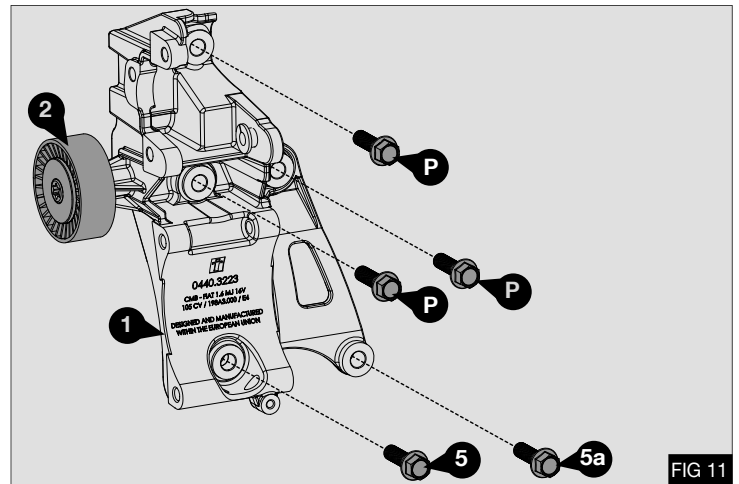



- Install the mount bracket  to the engine block using three OE M10 bolts  , and two M10 x 35 flange bolts  and  - Fig 11
- Torque bolts OE M10 x45 bolts  58 Nm / 42.7 lb.ft and M10 x 35 bolt  and  58 Nm / 42.7 lb.ft - Fig 11
- Now loosen the M10 x 35 flange bolt  and temporarily remove to allow access - Fig 11





### COMPRESSOR INSTALLATION

- Fit the supplied compressor manifold fittings  and  and clamp  with M10x35 bolt  - Fig 12

**NB:** Do not fully tighten clamp bolt  at this stage.



- Mount the compressor to the bracket  using four M10 x 30 set screws  - Fig 12

**Note:** It is advisable to do the back top set screw from the top side of the engine.

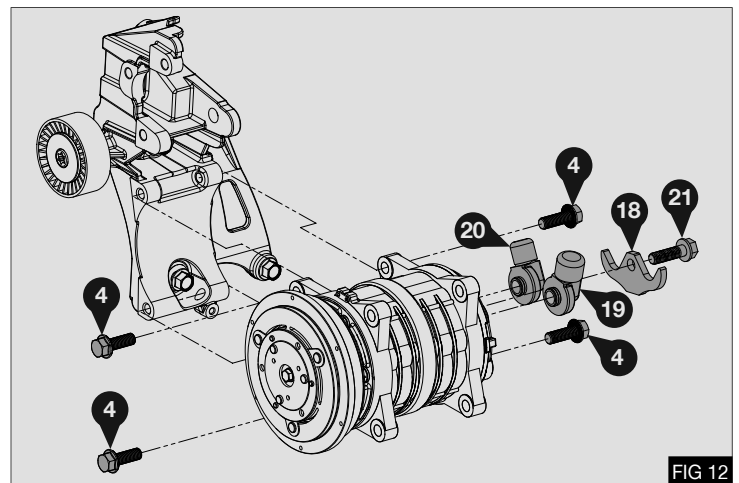
- Replace the M10 x 35 flange bolt and washer  back into the mount hole that it was removed from.
- Torque the bolts M10 x 30 set screw  58 Nm / 42.7 lb.ft and M10 x 35 bolt  58 Nm / 42.7 lb.ft - Fig 12





### PAS INSTALLATION

1. Secure the PAS pump , minus the rotor, to the mount bracket  using the OE M8 socket head bolts  and washers - Fig 13

**Note:** It is easier to put the PAS pump  into position from the top side of the engine.

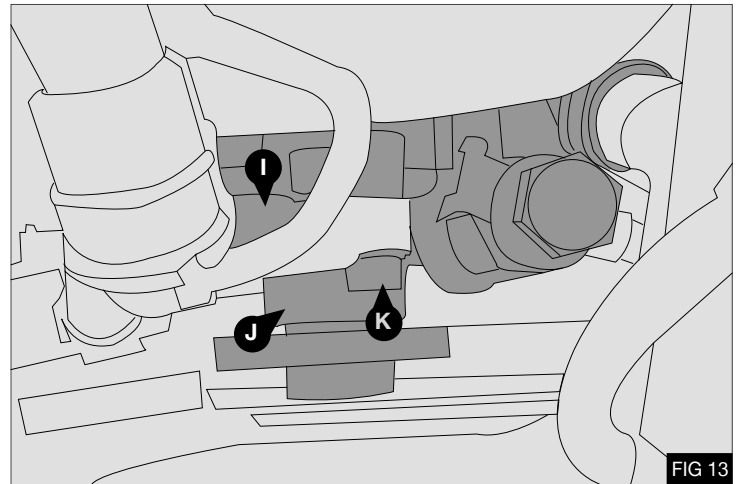
2. Torque OE M8 socket head bolts  to 29 Nm / 21.4 lb.ft - Fig 13





3. Re-install the PAS pump rotor  to the PAS pump  using the OE bolts - Fig 14

4. Torque the OE bolts to 29 Nm / 21.4 lb.ft - Fig 14

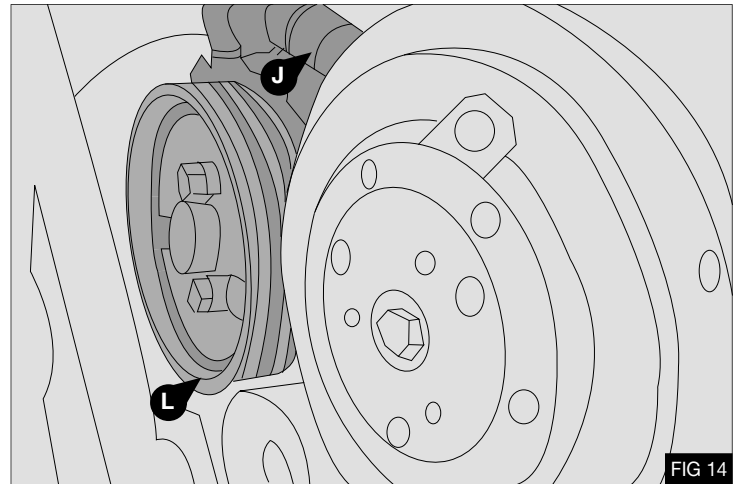
**Warning :** Check PAS pump rotor  is fitted correctly, it is possible fit the wrong way round





### CLUTCH ROTOR INSTALLATION

1. Install the compressor rotor  to the compressor using six M5 socket head set screws  and spring washers  - Fig 15

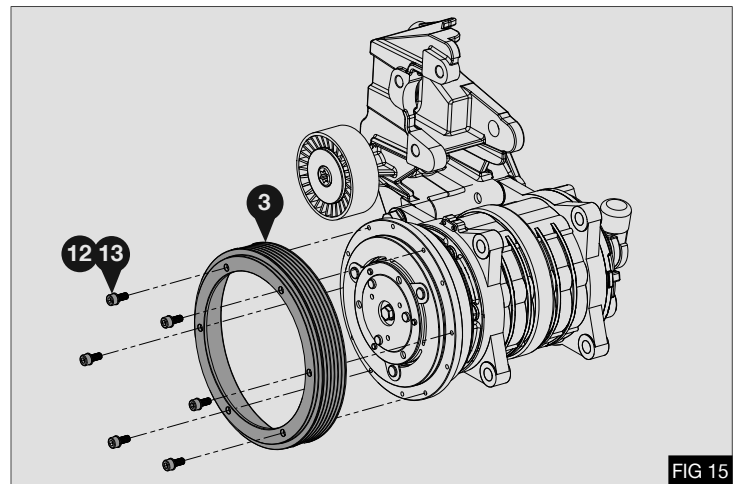
2. Torque M5 socket head set screws  to 7.1 Nm / 5.24 lb.ft - Fig 15



### POST INSTALLATION

1. Secure the PAS pipe support bracket  to the main mount bracket  using the OE M6 bolt and washer  - Fig 16

2. Torque OE M6 bolt  to 12 Nm / 8.85 lb.ft - Fig 16

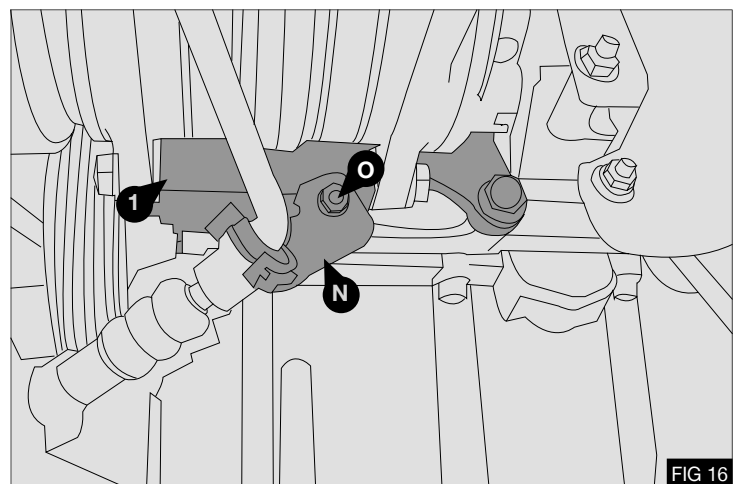

3. Connect refrigerant hoses as shown, once hoses are positioned correctly torque bolt (21) to 45Nm/33Lbft - Figs 17 & 12

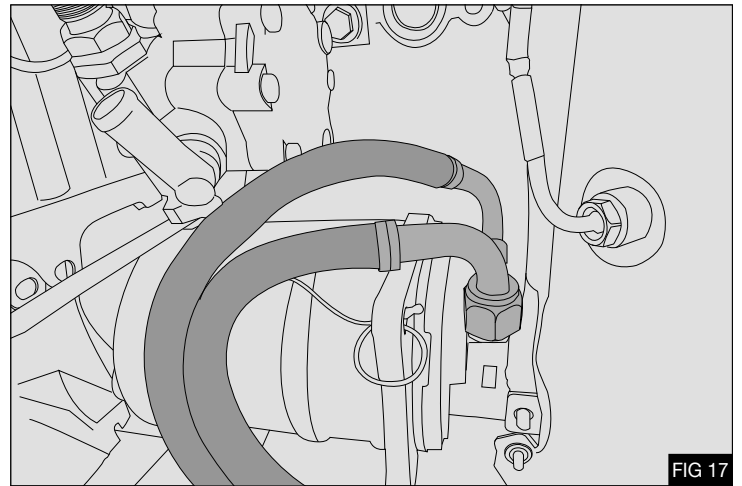

4. Re-fit hose assembly (D) - Fig 18

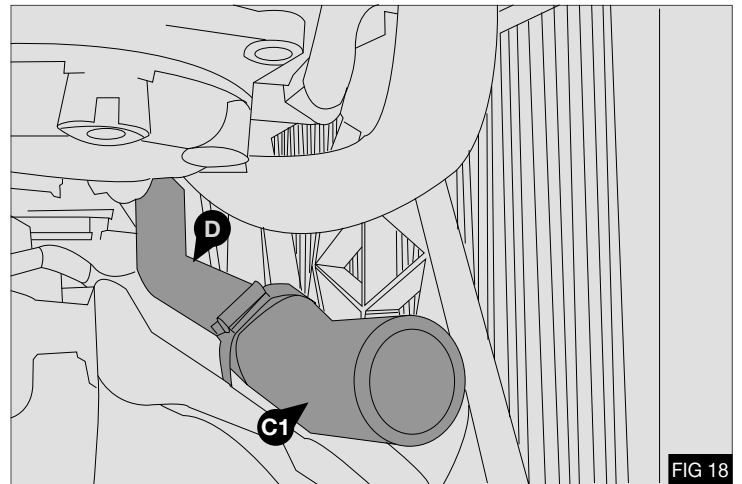

5. Secure the lower metal air pipe (F) to the air pipe support bracket (6) using one M6 x 30 bolt (16) going through the air pipe (F) support bracket and being secured in place with one M6 nut (8) onto one M6 flat washer 25mm (7) - Fig 19
6. Secure the air pipe support bracket (6) to the chassis stud (H) using an M6 nut (8) - Fig 19

**Note:** Do not torque nuts at this time.

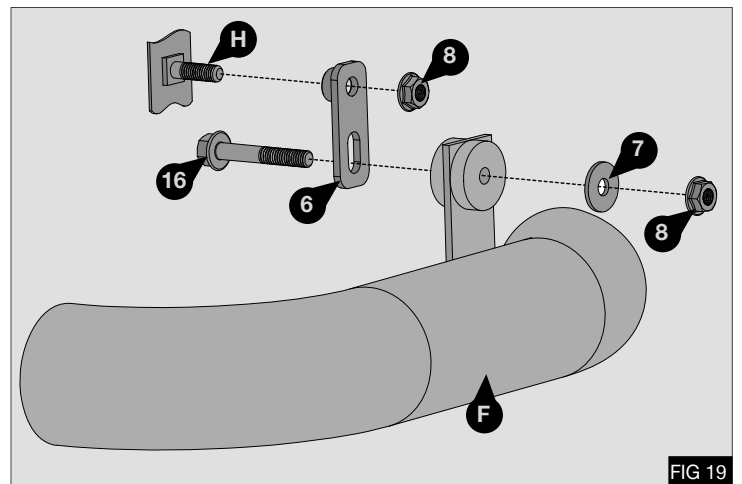

7. Secure the lower metal air pipe (F) to the chassis using one M6 x 40 bolt (9) going through the air pipe spacer (10) - Fig 20
8. Torque the M6 x 40 bolt (9) and M6 x 30 bolt (16) to 12 Nm / 8.85 lb.ft.

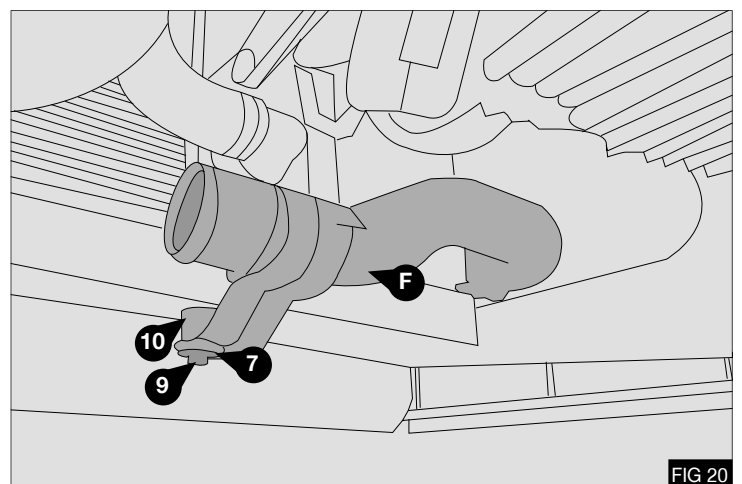

9. Secure the Air hose connector (14) to the bottom half of the cut rubber air hose (C2) using one 40-60mm pipe clip (15) - Fig 21
10. Place one 40-60mm pipe clip (15) to top half of the hose assembly (C1) - Fig 21

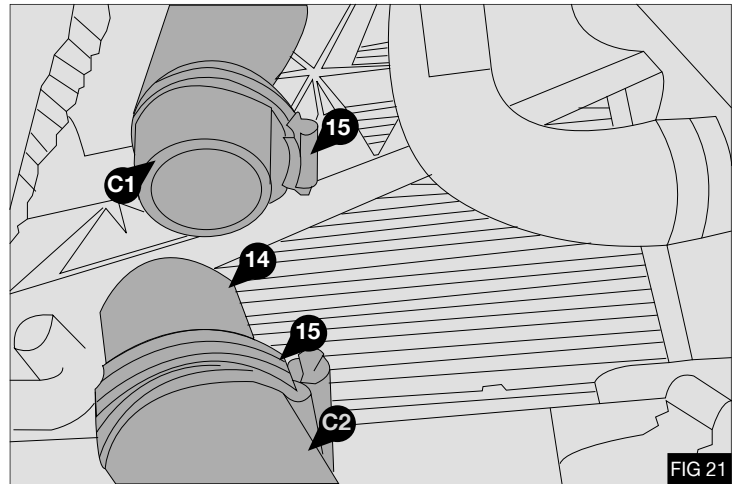

11. Fit the bottom half of the cut hose (C2) to the top half of the cut hose (C1) leaving a gap between (C1) & (C2) to allow for the whole hose assembly to be extended - Fig 22
12. Secure both halves together with the top 40-60mm pipe clip (15) - Fig 23

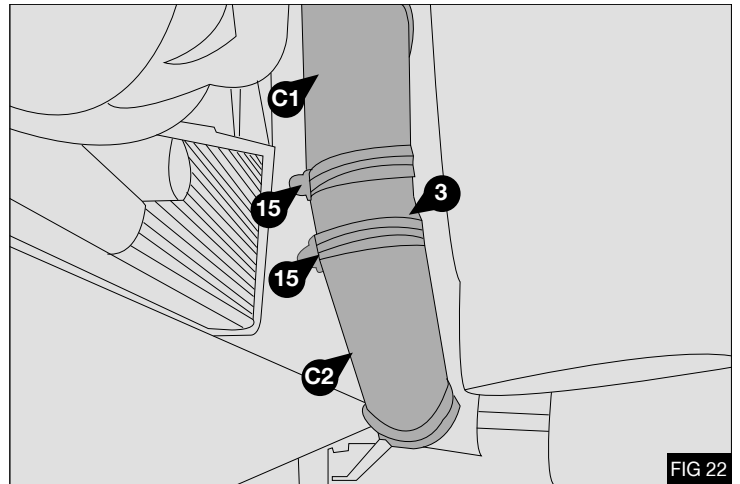

13. Secure the newly assembled air hose to the lower metal air pipe (F) using one 40-60mm pipe clip (15) - Fig 23

**Note:** Pipe clip (15) torque cap is designed to break off at the correct torque to allow for the expansion and contraction of the spring.

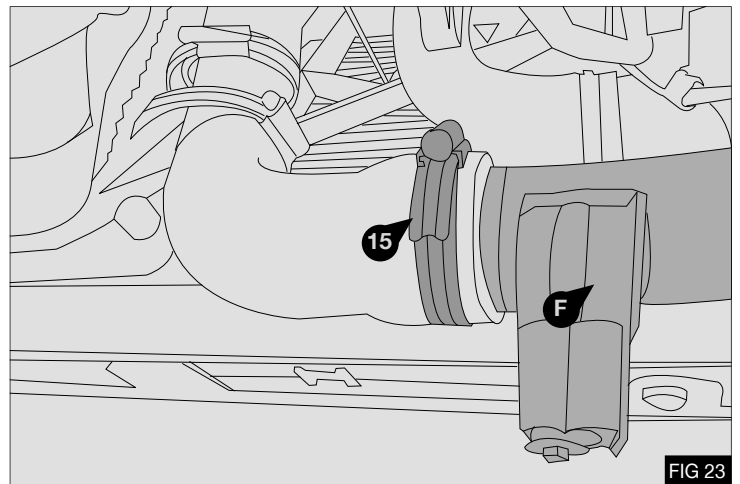

14. Re-fit the turbo hose (A) using the original clic - R® pipe clips (B) - Fig 24

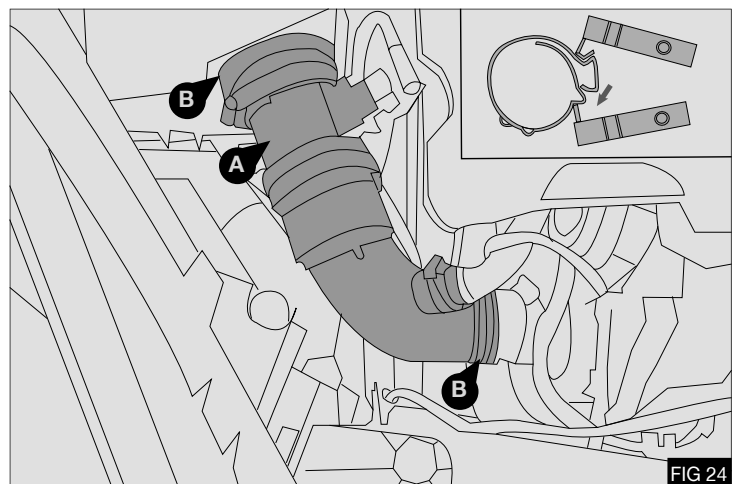

**DRIVE BELT**

15. Fit the belt provided (11) as shown in the diagram - Fig 25

- A Crank Pulley
- B Automatic Tensioner
- C Alternator
- D Idle Pulley
- E PAS Pump
- F Compressor
- G Idle Pulley

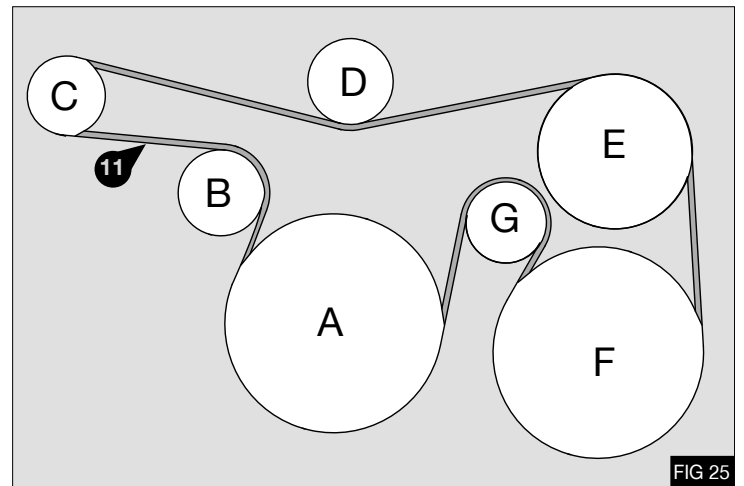

FIG 25

16. Install heat shield (17) and secure using original nuts (R) and (S)  
Position exhaust heat shield between the tab and the plate as shown - Fig 26

**FINISH**

Run the engine with the compressor clutch engaged for five minutes, check all components and fit belt label.

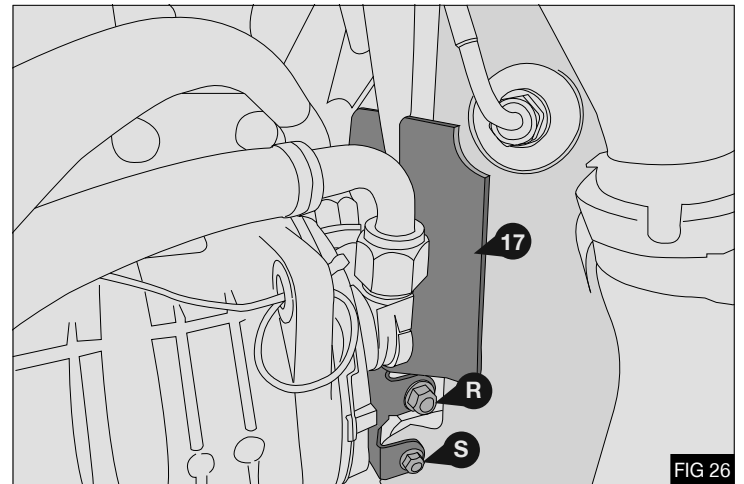

FIG 26



(EN)

Techni focuses on constant upgrading of its products. The Manufacturer reserves the right to modify the models and components described in the present publication at any time for technical or commercial reasons and without prior notice. For further information, contact Techni technical services.

(DE)

Techni ist stets bestrebt die eigenen Produkte zu verbessern. Die Herstellerfirma behält sich das Recht vor, aus technischen oder Verkaufsgründen, zu jeder Zeit und ohne vorherige Ankündigung, Abänderungen an den Modellen und den in dieser Veröffentlichung beschriebenen Einbauteile vorzunehmen. Für weitere Informationen bitten wir Sie, sich an unseren Techni Kundendienst zu wenden.

(FR)

Techni vise à une amélioration constante des ces produits. La maison se réserve le droit d'apporter, à tout moment et sans préavis, des modifications aux modèles et aux composants décrits dans cette publication pour des raisons d'ordre technique ou commerciale. Pour d'ultérieures informations s'adresser au service d'assistance Techni.

(IT)

Techni mira ad un costante miglioramento dei propri prodotti. La Casa si riserva il diritto di apportare in qualunque momento e senza preavviso modifiche ai modelli e ai componenti descritti in questa pubblicazione per ragioni di natura tecnica o commerciale. Per ulteriori informazioni rivolgersi al servizio assistenza Techni.

(ES)

Techni aspira a un constante mejoramiento de su producción. La Fábrica se reserva el derecho de aportar en cualquier momento y sin preaviso modificaciones a los modelos y los componentes descritos en esta publicación por razones técnicas o comerciales. Para ulteriores informaciones dirigirse al servicio asistencia Techni.

VENDITA E SERVIZIO  
VENTE ET SERVICE

SALE AND SERVICE  
VERKAUF UND SERVICE



Sundorne Trade Park, Henley Way,  
Shrewsbury, United Kingdom, SY1 4NS  
Telephone (+44) (0) 1743 443176  
Fax (+44) (0) 1743 443113  
Email: [sales@techni.co.uk](mailto:sales@techni.co.uk)